

Part number

CMAP 03 CS



Brief description:

surface mounting housings with 4 pegs, size "57.27" insulated 830V, metal cover, Pg21, insulated 830V version, IP65

Product description

Version	insulated 830V version
Series	Surface housings, with 4 pegs
Product type	with 4 pegs and gasket
Variant	metal cover
Style	high construction
Family	830V enclosures for CME inserts
Size	size "57.27" insulated 830V

Technical data

Operating temperature range (min, max)	-40°C ... +125°C
Material	metal
IP degree of protection	IP65
Cable entry	Pg21

Further technical details

Weight	305,00 g
---------------	----------

Approvals / Standards

Quality mark	 (type:4/4X/12),  , EAC
Conformity	CQC, CE

General ordering information

EAN13 code	8015747028981
Tariff number	85369095

Packaging Information

Sub-packaging weight	0,31 kg
Sub-packaging description	Plastic packaging
Sub-packaging quantity	1 Pcs
Sub-packaging EAN barcode	8015747028998

Part number

CMAP 03 CS



Catalogue drawings

CMP CMAP - MMP MMAP

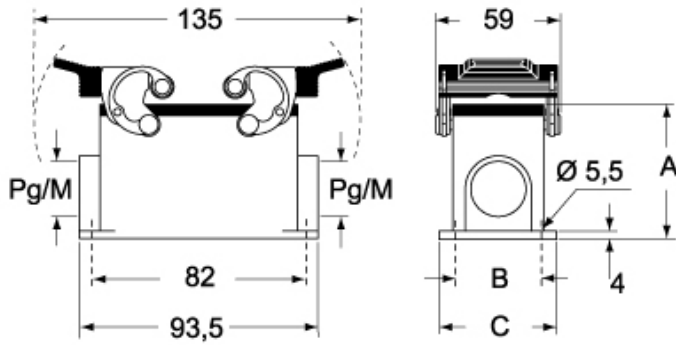

CMP CS/CP CMAP CS/CP - MMP CS/CP MMAP CS/CP

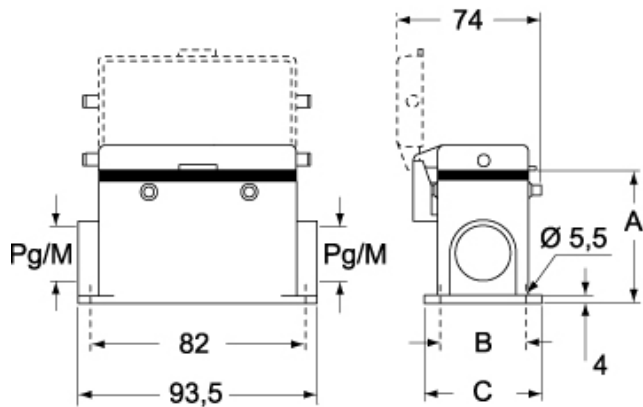

	A	B	C
CMP / MMP	57	40	52
CMAP / MMAP	73	45	57
CMP CS / MMP CS	57	40	52
CMAP CS / MMAP CS	73	45	57
CMP CP / MMP CP	57	40	52
CMAP CP / MMAP CP	73	45	57